

EPR-X1

Powered Air Purifying Respirator



ESAB's EPR-X1 PPR unit connects seamlessly with all current **ESAB prepared for air** welding helmets and provides advanced respiratory protection from harmful welding fume particulates.

This PPR is designed for applications ranging from occasional use to full-time industrial applications. The EPR-X1 offers a robust, compact housing with a powerful blower to ensure maximum life and performance. Check your battery status, fan settings and filter conditions at a glance with quick-access status LED lights. Additionally, the PPR provides audible and vibratory alerts to notify the user of low air flow (indicating a needed filter change) and low battery conditions.

The EPR-X1's turbo unit is controlled with easily-accessed push buttons allowing three airflow speed ranges of 170/190/220 l/minute. The HEPA-quality, EN12942 TH-3P certified two-stage filter and spark arrestor are easily accessed through a removable front door.

Industry

- Agricultural Equipment
- Automotive
- General Manufacturing
- Heavy Fabrication
- Industrial and General Fabrication

- Compatible with all ESAB prepared for air helmets: Sentinel A-50; Savage A-40; G-30/40/50; F-20
- User adjustable air flow 170/190/220 l/min
- Li-Ion battery pack (up to 10h duration @ 170 l/min)
- P3 filter and pre-filter
- International intelligent charger (interchangeable pins)
- Audio/visual/vibration blocked filter and low battery alarm

Visit **esab.com** for more information.



EPR-X1 PPR System



EPR-X1 with Savage A-40 Air Helmet

EPR-X1

Specifications

Air Flow	Selectable 170; 190; 210 l/min (6 - 7.8 cfm)
Battery Time	Up to 10h @ 170 l/min (7.8 cfm)
Filter	P3 filter and pre-filter with replaceable spark arrestor
Certifications	CE EN12941 TH3 P
Dimensions LxHxW	210 x 169 x 78 mm (8.3 x 6.7 x 3.1 in.)
Weight	1 kg (2.2 lbs)

Ordering Information

EPR-X1 PAPR system with expandable hose	0700500900
---	------------

For more information on helmets please see separate fact sheets or manuals.

Wear and Spare Parts

1	EPR-X1 PAPR Blower Unit	0700500901
2	EPR-X1 PAPR Prefilter	0700500902
3	EPR-X1 PAPR P3 Filter	0700500903
4	EPR-X1 PAPR Battery	0700500904
5	EPR-X1 PAPR Filter Cover	0700500905
6	EPR-X1 PAPR Spark Arrestor	0700500906
7	ESAB Breathing Tube for EPR-X1pen PAPR	0700500907
8	Anti-fire Cloth of Breathing Tube for EPR-X1pen PAPR	0700500908
9	Waist Belt and Shoulder Harness	0700500909
10	Universal Battery Charger	0700500910

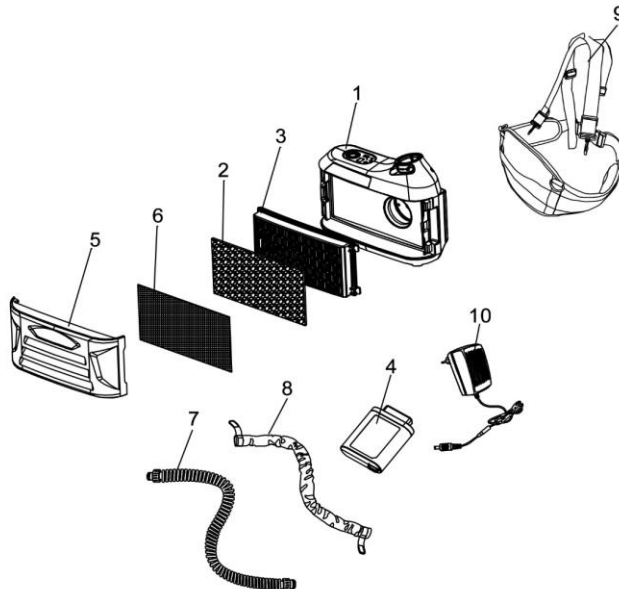

ESAB / esab.com

